



S40 Advance Series II / S50 Advance Series II
Thermal
Life-support
Cabinet

User instructions - Medical intensive care unit for mammals, reptiles and birds.

Contents

Section	Subject	Page
1	Introduction	2
2	QUICK REFERENCE	2
3	Unpacking	4
4	Location and Assembly	5
5	Digital Control System	7
6	Temperature	9
7	Humidity and Ventilation	9
8	Fan Speed Control	10
9	Small Animal Care	10
10	Internal Lighting	12
11	Cleaning up	12
12	Servicing and Calibration	13
13	Specification	14



**Read instructions
before use.**



Danger. Not intended for use with oxygen gas. Use of oxygen creates a fire hazard.

Damaged appliances shall not be used.

The appliance and its supply cord must be placed in an indoor area not subject to splashes of water or wet conditions and protected from or out of reach of animals.

Repairs shall be carried out only by a suitably qualified person.

This appliance shall not be used, cleaned or maintained by children or persons with reduced physical, sensory or mental capabilities or lack of experience and knowledge without supervision. Children shall not play with the appliance.

Disconnect the ICU from the mains power supply during cleaning. Ensure that all electrical parts are kept dry. Avoid alcohol-based solutions and make sure that all disinfectant is thoroughly rinsed off plastic parts with clean water. Disinfectant solutions may cause severe cracking of plastic if not correctly rinsed off.

Record your appliance serial number here: _____

IMPORTANT NOTICE

Brinsea Products Inc and its agents or distributors will not be responsible for loss of animals in the event of failure however caused and the user is advised to arrange his own insurance cover where loss of power or mechanical or electrical failure might result in unacceptable losses.

1 Introduction

Congratulations on the purchase of your new Vetario Intensive Care Unit. The Vetario S40 Advance Series II and S50 Advance Series II provide the ideal veterinary intensive care environment for peri-operative patients sensitive to hypothermia, shock and other post-operative complications. These products give patients the best possible chance of a successful recovery.

These instructions detail the operation of your new Vetario intensive care unit. Please read them carefully before setting up your unit to achieve best results and keep these instructions safe for future reference. Your intensive care unit is designed to allow the user to vary the environmental conditions to suit recovery of a wide range of species and the specific set-up for every recovery scenario is beyond the scope of these instructions. There are a range of books and veterinarian texts available covering animal recovery techniques.

The principal applications for the S40 and S50 are as an advanced intensive care unit for sick, injured or post operative animals and birds.

To register your new Brinsea product please visit www.brinsea.com and follow the link under Customer Service on the top navigation of the home page to qualify for your free 3 year warranty. If you do not have access to the internet please call 1-888-667-7009.

Fig. 1 Functional features of the Vetario S40 Advance Series II and S50 Advance Series II (40 model shown)

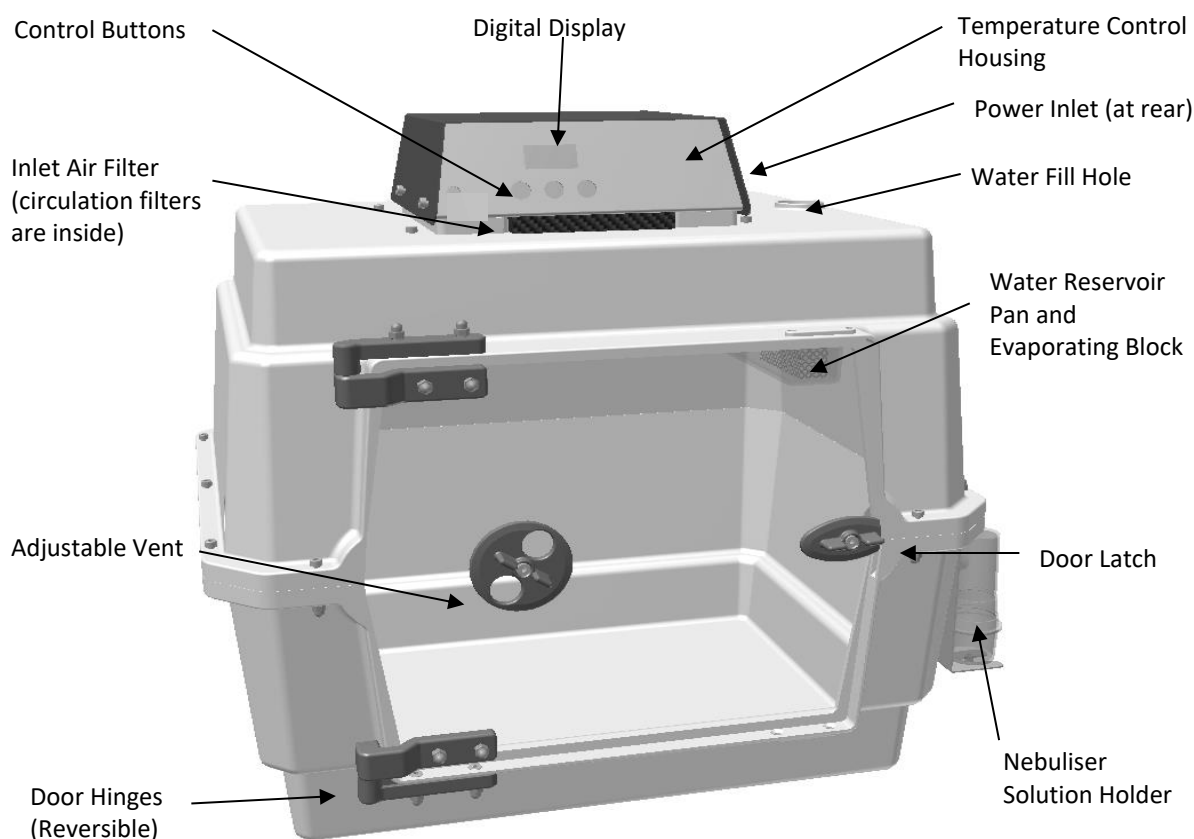





2 Quick Reference (please read relevant section for detail)

This quick reference is intended to allow users familiar with Vetario ICUs to quickly set up the ICU and learn the key features of the control system. Please read the rest of the instructions to obtain a full understanding of each feature. **DO NOT COVER THE ICU. FOR INDOOR USE ONLY.**

- 1) Carefully unpack the ICU parts (section 3)
- 2) Assemble the cabinet (section 4)
- 3) Fit the power lead

MAIN MENU – QUICK REFERENCE

	PRESS BOTH BUTTONS TO UNLOCK THE MAIN MENU
	SELECT THE OPTION / RETURN TO THE MENU.
	GO FORWARD ONE SCREEN / INCREASE THE VALUE / DISPLAY IN CELSIUS.
	GO BACK ONE SCREEN / DECREASE THE VALUE / DISPLAY IN FAHRENHEIT.

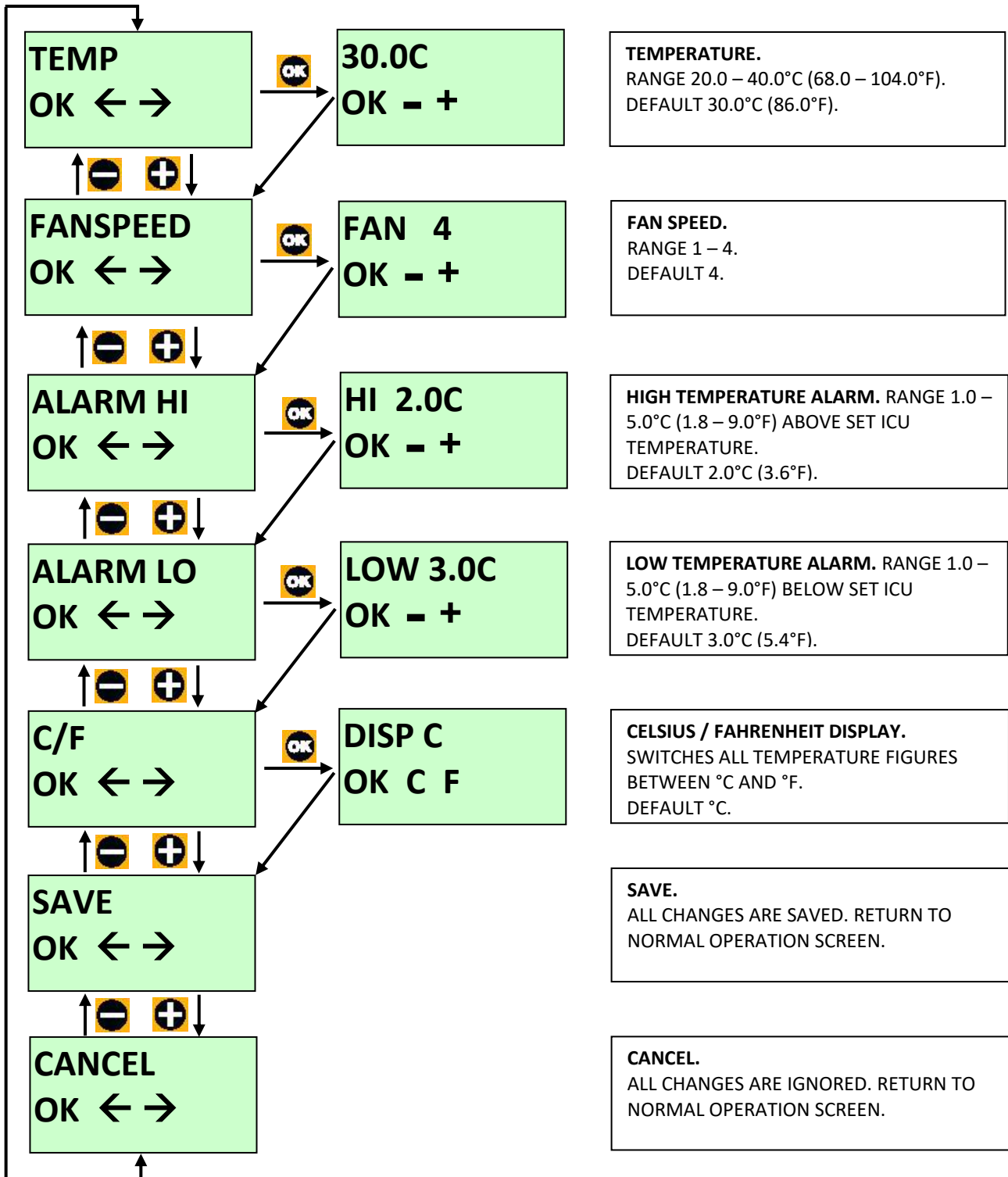

3 Unpacking

Your ICU has been supplied in protective packaging. Please remove all tape, strapping and packing from the ICU and parts. Retain the carton and packing materials to enable the unit to be repacked.

Your ICU will include as standard:

Quantity	Item
1	ICU top assembly (with 3 air filters fitted)
1	Cabinet base
1	Door
1	Hinge socket
1	Fastener and tool kit
1	Mains cable
1	Water pan
1	Evaporating block
1	Water funnel
1	Nebuliser solution holder
1	Nebuliser bracket

Fastener and Tool Kit Contents:

Quantity S40	Quantity S50	Item
2	2	 M5 x 16mm countersunk screws
2	2	 M5 flat washers
2	2	 M5 domed nuts
12	16	 M4 x 30mm cap-headed screws
12	16	 M4 star washers
12	16	 M4 nuts
1	1	 Door edge strip
1	1	 Nebuliser hole grommet
1	1	3mm hex key
1	1	4mm hex key
1	1	7mm / 8mm wrench

3.1 Please identify each part and check that they are all present and undamaged. If there are any parts damaged or missing please contact your retailer or Brinsea Products (at the address at the end of the document).

3.2 Check also that the electrical supply matches the machine's requirements (marked on the technical label next to the power inlet socket).

4 Location and Assembly

- 4.1 Your ICU will give best results in a room free from wide temperature variations and with generous ventilation – particularly if several ICUs are running at the same time. Ensure that the room temperature cannot drop on a cold night. Ideally thermostatically control the room at between 68 and 77°F (20 and 25°C). Never allow the room temperature to drop below 59°F (15°C) and ensure that the ICU cannot be exposed to direct sunlight.
- 4.2 Assemble the cabinet using the tools and fasteners provided. Follow the diagrams. Do not over-tighten fasteners.
- 4.3 The door is hinged at the left as supplied but may be reversed to provide better access if required. Fit the top hinge socket to the cabinet using the M5 x 16mm countersunk screws, M5 flat washers and M5 dome nuts.

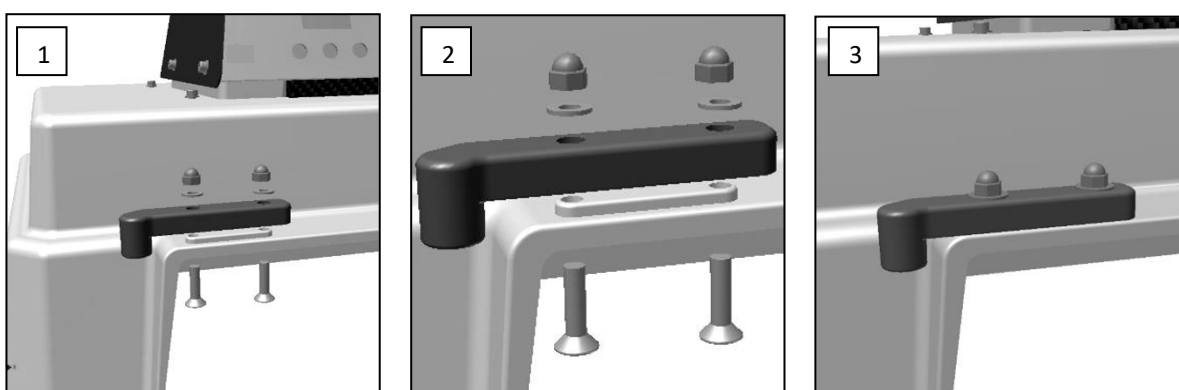

- 4.4 Place the door in the lower hinge and close the latch. Lower the top cabinet down onto the other parts.

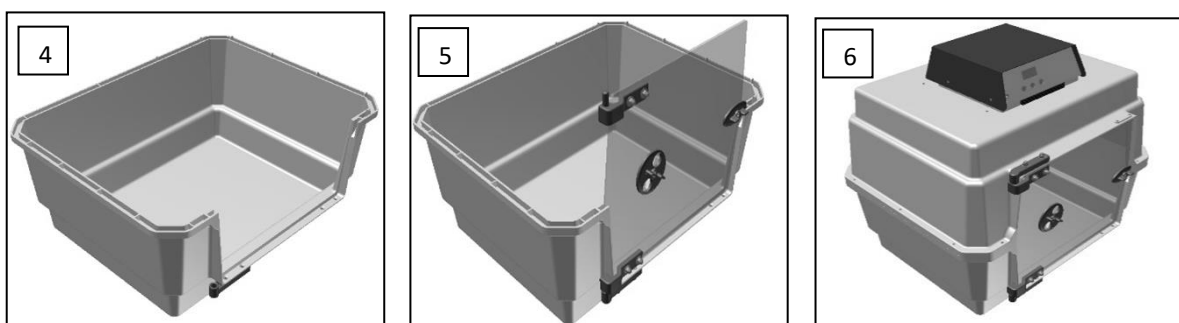

Fit the M4 x 30mm cap-headed screws, star washers and nuts into each set of holes around the edge of the cabinet. Tighten enough to prevent them spinning. This creates an air tight seal around the cabinet. If the nebuliser is required, fit the nebuliser bracket as shown (8a). If the nebuliser is not required fit the grommet first and secure it with the bracket (8b).



- 4.5 If caring for small animals with long claws such as hedgehogs, the door edge strip may be fitted as shown to ensure claws cannot pass through any door gap:

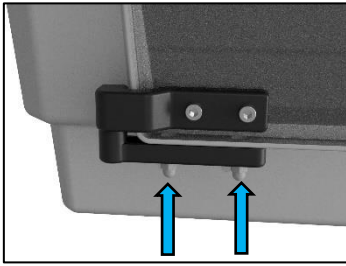

Loosen the bottom hinge/cabinet fixings by half a turn so that the hinge becomes free to move.

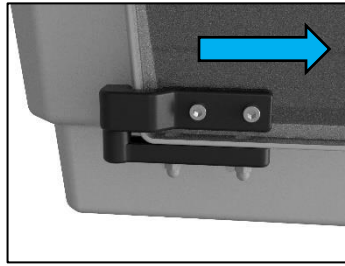

Slide the door as far as it will go in the direction of the door latch. Tighten the fixings while holding the door.

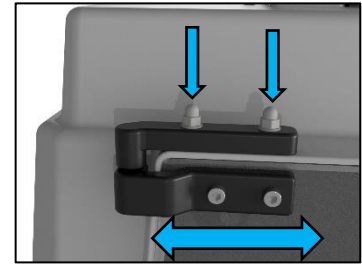

Loosen the top hinge/cabinet fixing. Move it so that the door becomes level in the frame and opens/closes freely. Tighten the fixings.

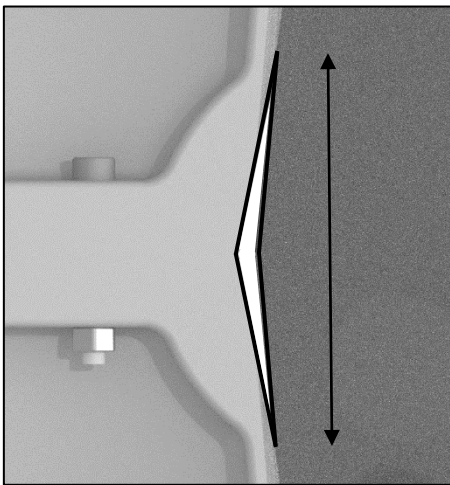

Observe the length of any 'V' shape gap that a claw could fit through. Cut the door edge strip to fill the length of the gap.

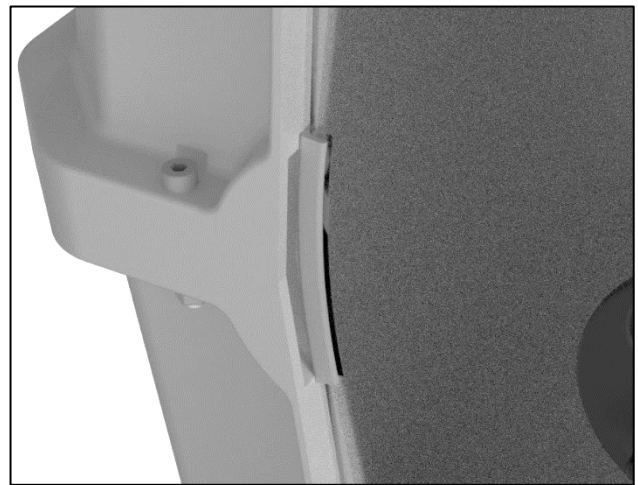

Open the door wide and press the door edge strip into place on the door. Close the door and check the strip does not force the door outward. Trim the length of the edge strip if necessary.

- 4.6 Place the white evaporating block in the clear water pan. Open the door and lift the pan into position, it pushes up and across into two slots on the heater enclosure. The pad may need to be softened with a little water to help it flatten while the pan is fitted. The pan is located in this manner to help prevent accidental removal by animals.

Air Filter

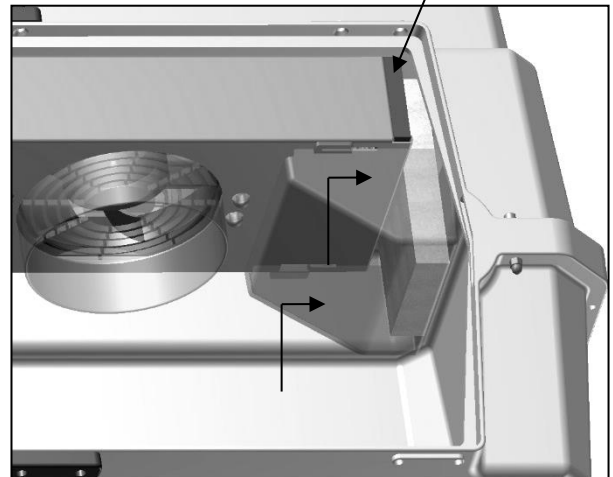
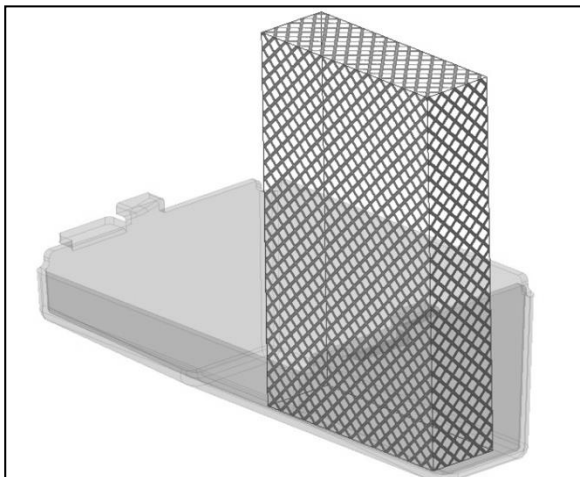

- 4.7 Your ICU is supplied with air filter media fitted at the air inlet (see fig 1) and at each end of the heater enclosure (see picture 9 above). For details of filter replacement see the Servicing section.
- 4.8 Fit the nebuliser solution holder by inserting the "mouthpiece" through the hole in the cabinet and locating the solution holder pipe in the slot in the bracket.
- 4.9 Place the ICU on a scratch and moisture resistant surface. Worktop height is ideal.
- 4.10 Connect the mains cable to the inlet. Ensure the connector is pushed fully home in its socket.
- 4.11 The fan will start and the display will show the current temperature and humidity in the cabinet plus a "P" symbol to show power was interrupted.
- 4.12 Allow the ICU to run for at least an hour to stabilise the temperature before introducing animals.

5 Digital Control System

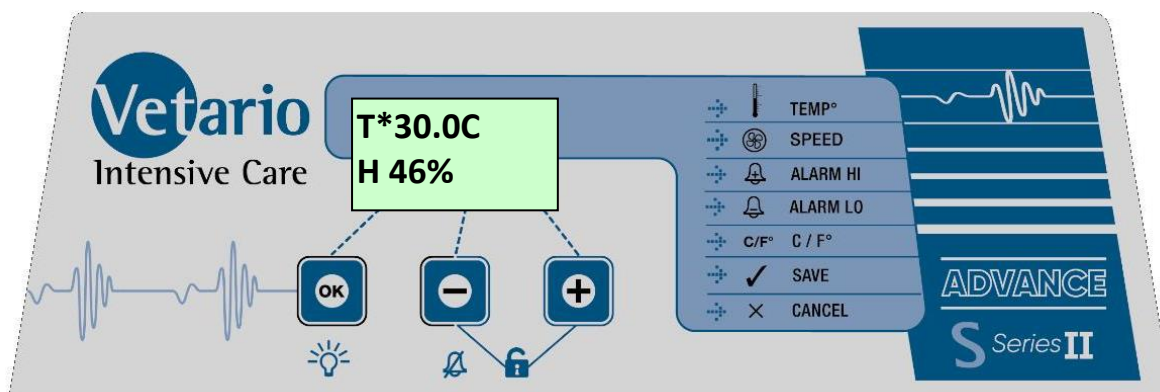

The Vetario Advance Series II control system utilises highly accurate, individually calibrated sensors for temperature and humidity. Be cautious of low-cost analogue or digital thermometers and hygrometers when comparing them with the ICU display readings.

- 5.1 NORMAL OPERATION – Temperature and relative humidity are continuously displayed.

The asterisk "*" adjacent to the temperature reading shows when the heater power is on. When warming the asterisk will be continuously on, once warmed up the asterisk will slowly flash as the heater is pulsed to maintain the correct temperature.

- 5.2 POWER LOSS DISPLAY – If power has been interrupted due to a power cut (or when first switching on) a "P" is shown flashing in the corner of the display. Press the - or + button for 2 or more seconds to clear the indicator. If the reason for the power loss is not known check the power cable connections are secure.

T*30.0C
H 40% P

- 5.3 HIGH INCUBATION TEMPERATURE ALARM DISPLAY – If the measured temperature goes up by more than the figure in the ALARM HI screen, the alarm will sound immediately and “H” will be displayed. Press OK to silence the alarm for 30 minutes.

If the high temperature problem rectifies itself the “H” remains on the display to show this has happened. Press OK to clear the indicator. Check the ICU is not (and has not been) in direct sunlight or too near a heat source such as a room heater.

T 39.8C
H 23% H

- 5.4 LOW INCUBATION TEMPERATURE ALARM DISPLAY – If the measured temperature goes down by more than the figure in the ALARM LO screen, after 1 hour “L” will be displayed and the alarm will sound. Press OK to silence the alarm for 30 minutes.

If the low temperature problem rectifies itself the “L” remains on the display to show this has happened. Press OK to clear the indicator. Check the ICU is not (and has not been) in a cold draught or that the room temperature has dropped significantly.

T*32.1C
H 45% L

- 5.5 HIGH ROOM TEMPERATURE ALARM DISPLAY – If the calculated room temperature remains too high for stable temperature control for more than 1 hour a warning is displayed “+RM” and an alarm will sound. Press OK to silence the alarm for 30 minutes.

If the high temperature problem rectifies itself the “+RM” remains on the display to show this has happened. Press OK to clear the indicator.

Check the ICU is not (and has not been) in direct sunlight or too near a heat source such as a room heater. The animals themselves create significant metabolic heating and may contribute to this if room temperature is high.

T 36.0C
+RM

- 5.6 LOW ROOM TEMPERATURE ALARM DISPLAY – If the calculated room temperature remains too low for stable temperature control for more than 1 hour a warning is displayed “-RM” and an alarm will sound. Press OK to silence the alarm for 30 minutes.

If the low temperature problem rectifies itself the “-RM” remains on the display to show this has happened. Press OK to clear the indicator.

Check the ICU is not (and has not been) in a cold draught and that the room temperature has not dropped significantly.

T*36.0C
-RM

- 5.7 CHANGING SETTINGS – The Main Menu allows the various settings to be modified and saved. All changes are retained in the event of a power cut.

To access the Main Menu, press the + and – buttons simultaneously to unlock the display. For full details of menu settings please refer to the guide on page 3.

6 Temperature

Stable and correct temperature is essential for good results. Adjust with care.

WARNING:- THE CIRCULATING FAN AND THE METABOLIC HEAT FROM PATIENTS CONTRIBUTE HEAT TO THE ICU. THE ICU MAY NOT CONTROL PROPERLY IF THE ROOM TEMPERATURE IS LESS THAN 10°F (3°C) LOWER THAN THE TEMPERATURE REQUIRED INSIDE.

AVOID LEAVING THE DOOR OPEN AS THIS WILL CREATE SIGNIFICANT DISTURBANCE OF THE TEMPERATURE IN THE ICU AND TAKE TIME TO STABILISE.

- 6.1 Note: your ICU may not be set to the correct temperature from the factory and the following procedure must be followed before introducing animals.
- 6.2 Press the - and + buttons simultaneously to unlock the main menu. Press OK to select the temperature screen and adjust as necessary using the + and – buttons. Press OK to return to the Main Menu and then scroll down to Save. Press OK to save the changes.
- 6.3 As the ICU warms up and approaches its control setting the heater on asterisk “*” will change from continuously on to flashing. When reducing temperature, the asterisk may still flash as the ICU gently cools – this is normal.
- 6.4 Refer to the digital temperature display to check temperature. The display shows the air temperature in increments of 0.1°.
- 6.5 The Display can be switched to show all temperature settings in degrees Fahrenheit. Press the - and + buttons simultaneously to unlock the main menu. Scroll to the C/F option and press OK to select the C/F display screen. Press the + button to select °F or the – button to select °C. Press OK to return to the Main Menu and then scroll down to Save. Press OK to save the changes.
- 6.6 For recommended temperatures see section 9. Note that the temperature should be gradually reduced to room temperature (20 – 25°C or 68 – 77°F) as the patient recovers to avoid sudden temperature change when the patient is removed.
- 6.7 Care should be taken about cooling that occurs during feeding or inspection or very small patients. Keep the room warm, hold the patient in a cloth to prevent chilling from cold hands and use warmed feeding utensils.

7 Humidity and Ventilation

*Elevated air temperatures in the ICU will reduce the relative humidity level (RH) and can cause dehydration. A water reservoir is fitted to counteract this effect. **Relative humidity of between 45 and 55% RH is adequate. Avoid very high levels as condensation may form on cooler surfaces. The maximum achievable humidity is subject to room conditions with a typical limit of approximately 65 to 70%RH.***

- 7.1 Your ICU is fitted with a water reservoir (see fig.1) which humidifies air as it is drawn into the heater enclosure. Use a solution of proprietary water-based disinfectant (diluted in accordance with the manufacturer's instructions) in the water reservoir (pan) to inhibit bacterial build-up. It is recommended

that the reservoir is topped up with solution daily to reduce dehydration. This can be a particular problem with chick(s).

- 7.2 The ICU and its occupants need not be disturbed to fill the water pan. Use the funnel provided to pour water through the water fill point in the top of the ICU (see fig. 1) directly onto the evaporating block and into the water pan. Push the funnel down gently into the hole to make sure the water pours directly in. Clean up any spilled water from the top of the ICU immediately.
- 7.3 To further increase humidity levels within the ICU the water reservoir is fitted with an evaporating block of absorbent paper mesh as standard. This block may be cut in half or removed entirely to give lower humidity levels if condensation forms. The block can provide a breeding ground for bacteria. In addition to the use of water-based disinfectant solution in the water, it is recommended that the block is replaced every 2 months of use.
- 7.4 An adjustable vent is fitted to the door of the ICU which may be opened or closed to give greater control of humidity (close vent to increase) and fresh air flow. The vent may be fully closed as fixed ventilation is also provided.
- 7.5 In order to maintain maximum air-flow the air-flow filters should be checked once a week for dust or down, and cleaned if necessary.

8 Fan Speed Control

The speed of the air circulation fan in Vetario Advance Series II ICUs may be adjusted between four levels. Higher fan speed provides the most accurate control of air temperature around the base of the ICU. Lower fan speed provides more gentle air flow around animals and lower noise level. The operator may choose the speed according to their priorities.

- 8.1 Press the - and + buttons simultaneously to unlock the main menu. Press + once to display the fan speed option and then OK to select. Adjust as necessary using the + and – buttons. Press OK to return to the Main Menu and then scroll down to Save. Press OK to save the changes.
- 8.2 The highest fan speed provides the most accurate correlation between the display temperature and the average temperature of the air low down in the animal chamber.
- 8.3 The lowest fan speed provides the lowest noise and air speed but the air temperature low down in the animal chamber may be slightly cooler than that on the display, particularly in a cold room.

9 Small Animal Care

- 9.1 Your ICU has been specifically designed for the care of injured or sick small animals. Animals should always be cared for following the instructions and advice given by your veterinary surgeon.
- 9.2 The first stage of treating a cold animal (hypothermia) is to prevent further heat loss, by wrapping the casualty in insulating materials such as blankets, bubble wrap or silver foil. It is recommended to pre-heat the ICU and allow the temperature to stabilise before adding young birds or small animals. If you are aware of an incoming animal patient, the ICU may be switched on so that it is ready for immediate use when the patient arrives.

- 9.3 Once the ICU is warmed to the correct temperature the animal can be transferred. The amount of bedding should be reduced at this stage to allow warming from the environment in the ICU. All animals will benefit from some bedding in the bottom of the cabinet such as an absorbent pad to help reduce soiling. Small animals such as fox or badger cubs can benefit from having a soft toy for company while single ducklings or pheasant chicks can be provided with a safe mirror. Wild animals may become very distressed when handled by humans. Place the ICU where there is minimal disturbance.
- 9.4 All small mammals and birds will benefit from being kept in an environmental temperature within their 'thermoneutral range'. This is the range of temperatures in which an animal expends no energy to maintain its body temperature. The thermoneutral temperatures for typical adult mammals and birds are given in table 1. For birds, the thermoneutral range depends upon size, with smaller birds requiring higher temperatures. Reptiles and amphibians should be kept within an 'activity temperature range' (ATR) in which it can control its body temperature. ATR values for typical reptiles and amphibians are also given in table 1.

Species:	Temperature range:
Mammals	59 – 68°F (15 – 20°C)
Medium and Large Birds	59 – 77°F (15 – 25°C)
Small Birds	68 – 86°F (20 – 30°C)
Very Small Birds	77 – 95°F (25 – 35°C)
Reptiles	68 – 86°F (20 – 30°C)
Amphibians	59 – 86°F (15 – 30°C)

- 9.5 Hypothermic adult animals should be warmed in the ICU set to their thermoneutral range. The temperature of both the ICU and the animal should be recorded at regular intervals. Careful monitoring and observation of the animal should be undertaken to ensure that it is not showing signs of distress. i.e. panting or shivering. These animals are also likely to be dehydrated and/or 'shocked' (hypovolaemic) so warming alone will not correct these things and may make them worse. All adult animals must therefore be provided with adequate fluid therapy at the same time as warming and veterinary care (in person, over the telephone or in written SOPs). Injured animals also require pain relief (analgesia) which can be prescribed by a veterinary surgeon.
- 9.6 If the animal will drink, then an oral rehydration fluid can be provided in a shallow bowl. If the animal will not, or cannot drink, then fluid must be given in other ways. In birds, rehydration fluids can most easily be provided by crop tubing, provided the bird can lift its head and swallow. In mammals, intravenous or intraosseous fluids are usually required to rehydrate patients. These must only be administered by a veterinary surgeon or veterinary nurse.
- 9.7 Only feed a poorly animal once it is warm and always start with liquids only. Do not place moist, solid food in the intensive care unit as it will rapidly go bad due to the warm environment.
- 9.8 Dependent animals (those that would naturally be in a nest) should be kept in the ICU set at 82.5-89.5°F (28-32°C) they are of an age where they can maintain their own body temperature when the heat can be reduced to the thermoneutral range for that species. Carefully observe their behaviour for signs of panting or shivering to help determine the best temperature for them at that stage. Very small baby animals may require an artificial fabric 'nest' to be created in the ICU, lined with paper towel.
- 9.9 Like adult animals, baby animals are frequently dehydrated upon arrival and should be fed with an oral electrolyte solution. They also frequently have a low blood glucose level (hypoglycaemia) and should be fed appropriately soon after the initial electrolyte feed. If the animal is unable to lift its head, and/or swallow, then it will need to be given fluids and glucose by injection – this should be under veterinary direction.

10 Internal Lighting

- 10.1 The Vetario Advance Series II ICUs are equipped with gentle, internal LED lighting for night-time inspection of animals and birds. The LED lamps are energy efficient, do not affect temperature and would not normally require replacement. Amber colour LED's do not produce UV light often associated with "white" LED's.
- 10.2 The LED lights are located to the left of the fan diffuser in the S40 size model and on both sides of the fan diffuser on the larger S50 model.
- 10.3 The lights may be switched on and off by pressing the OK button. This has a toggle action.

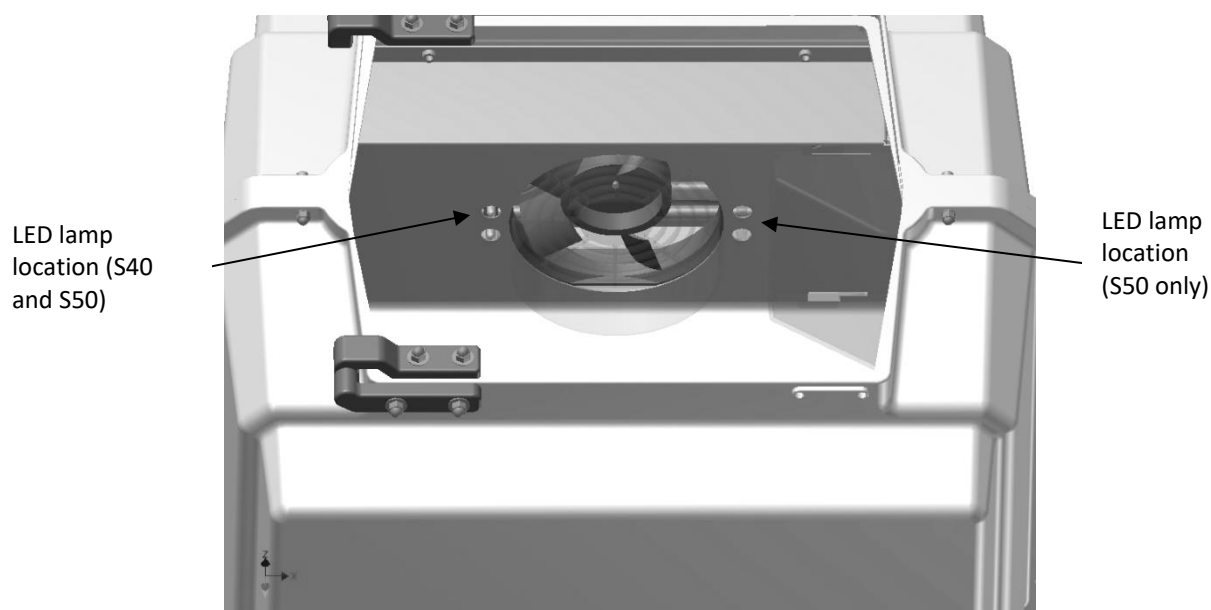

11 Cleaning Up

IMPORTANT:

DISCONNECT THE ICU FROM THE MAINS POWER SUPPLY DURING CLEANING. RISK OF ELECTRIC SHOCK!
ENSURE THAT ALL ELECTRICAL PARTS ARE KEPT DRY.

- 11.1 Following each use of your Vetario intensive care unit remove all debris from the floor. Wipe all internal surfaces with a soft cloth soaked in water-based disinfectant solution (diluted according to the manufacturer's instructions). Filters should be inspected on a weekly basis and be cleaned if necessary. Remove all three filters and gently hand wash in warm water then allow them to dry before use. Filters need replacing every six months. Immerse and soak any tubs in disinfectant solution. The exterior of the unit may be cleaned with a damp cloth.
- 11.2 Avoid alcohol-based solutions and make sure that all disinfectant is thoroughly rinsed off plastic parts with clean water. Disinfectant solutions may cause severe cracking of plastic if not correctly rinsed off.
- 11.3 Always clean the ICU before storage and ensure that the unit is totally dry inside and out or damage may occur to the components.
- 11.4 For deeper cleaning the base of the cabinet and the door may be removed by releasing the fasteners. See section 4 for assembly guide. The cabinet base and the door may be wet-cleaned with mild detergent and then disinfected with water-based disinfectant solution.

- 11.5 Replacement filters and evaporating blocks are available from Vetario Products at the address at the end of this document or from your Vetario agent.

12 Servicing and Calibration

- 12.1 Although it is not regarded as necessary for routine cleaning, the heater enclosure may be safely removed to allow the heater and fan to be dusted. Disconnect the power lead. Remove the water pan. Loosen the 4 cap-head screws (on top of the white plastic cabinet, not the grey control box) as shown and then finally remove each one while supporting the metal enclosure inside. The metal enclosure will fall if not held and may damage the ICU.
- 12.2 Carefully place the ICU on its top and then lift out the metal heater enclosure. The fan assembly may then be hinged over toward the front of the machine so that the heating element and fan blades may be dusted with a soft brush. USE NO LIQUIDS. DO NOT DISTURB THE TEMPERATURE SENSOR.

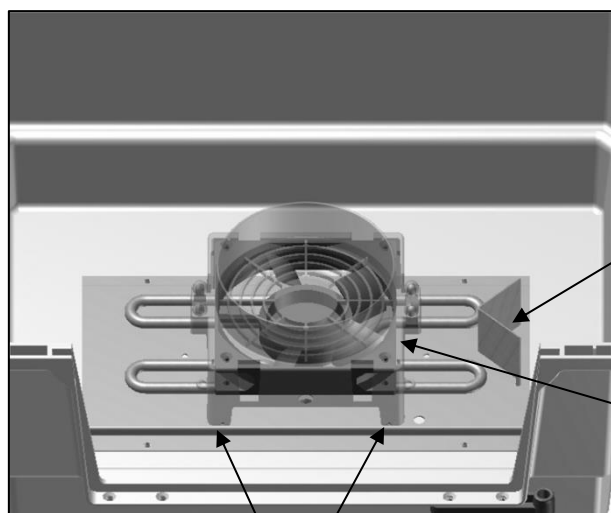
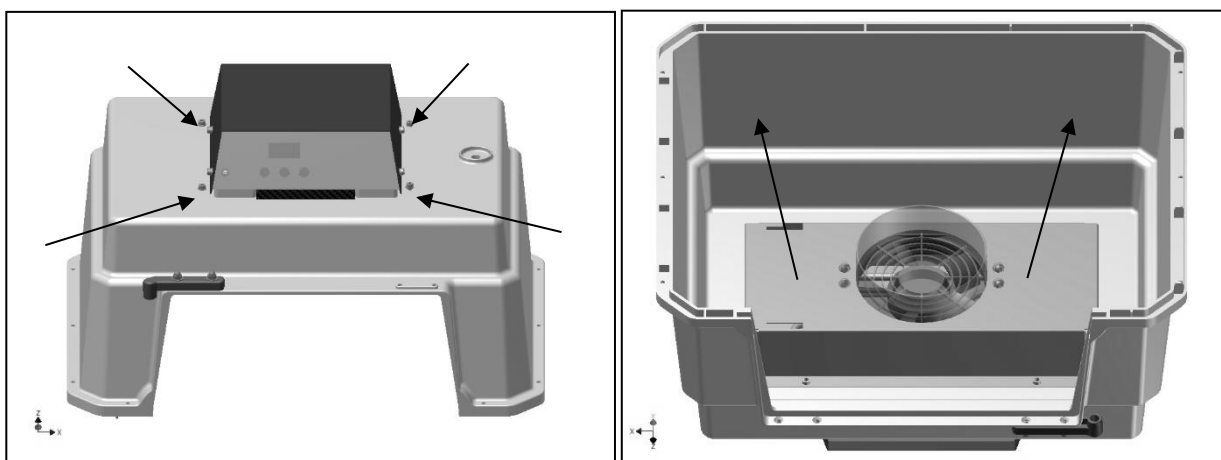

DO NOT DISTURB SENSOR

Fan assembly may be hinged out on its cables to allow fan and heater to be dusted with a soft brush

Fan assembly is located by 4 pegs in the feet of the clear moulding

- 12.3 Once the heater area has been dusted the fan assembly must be relocated by ensuring the 4 pegs on the clear moulding fit into the corresponding holes in the metal base plate.
- 12.4 ENSURE THE FAN / LED WIRES ARE NOT TOUCHING THE HEATING ELEMENT

- 12.5 Replace the metal cover so that the water pan slots are at the correct end. Hold the cover in place and fit the 4 cap-head screws. Do not over-tighten.
- 12.6 In case of failure first check that the mains power supply is working and that the mains cable connector is fully engaged in the socket at the rear of the control housing. Check the fuse in the mains inlet on the rear of the control housing. Replace with a fuse of the same type and rating if necessary.
- 12.7 If the problem persists contact your distributor or Brinsea Products Service Dept.
- 12.8 The digital temperature display is individually calibrated during manufacture but may be re-calibrated if required. In the unlikely event that that the accuracy of the temperature display is in doubt please ensure the air filters are cleaned and the heater enclosure is free of debris following the instructions above. Contact your distributor or Brinsea directly at sales@brinsea.com for further information and advice.

BE CAUTIOUS OF LOW COST ANALOGUE OR DIGITAL THERMOMETERS AND HYGROMETERS.

BRINSEA PRODUCTS LTD USES SOPHISTICATED EQUIPMENT TRACEABLE TO INTERNATIONAL REFERENCE STANDARDS.

13 Specification

	Vetario S40 Advance Series II	Vetario S50 Advance Series II
Overall height	18.5" (470mm)	21.5" (550mm)
Overall width	19" (485mm)	27" (690mm)
Overall depth	15" (385mm)	19.5" (490mm)
Floor area	15.5 x 12" (400x300mm)	23.5 x 15.5" (600x400mm)
Effective volume	10USgal (40L)	26USgal (100L)
Weight	15lbs (6.7Kg)	19lbs (8.7Kg)
Power consumption	85W typical, 150W max	100W typical, 150W max
Power supply	115V 60Hz or 230V 50Hz as ordered	

Vetario Products are manufactured by

Brinsea Products Inc., 704 N Dixie Ave., Titusville, FL 32796-2017 USA.
Phone. (321) 267-7009 Toll Free 1-888-667-7009 Fax (321) 267-6090
e-mail: support@vetario.com, website: www.vetario.com